



*LIGO Laboratory / LIGO Scientific Collaboration*

LIGO-T020020-00-D

*ADVANCED LIGO*

04/20/02

---

Input Optics Subsystem  
Design Requirements Document

---

G. Mueller, R. Amin, M. Rakhmanov, D. Reitze, D.B. Tanner, S. Wise

Distribution of this document:  
LIGO Science Collaboration

This is an internal working note  
of the LIGO Project.

**California Institute of Technology**  
**LIGO Project – MS 18-34**  
**1200 E. California Blvd.**  
**Pasadena, CA 91125**  
Phone (626) 395-2129  
Fax (626) 304-9834  
E-mail: info@ligo.caltech.edu

**Massachusetts Institute of Technology**  
**LIGO Project – NW17-161**  
**175 Albany St**  
**Cambridge, MA 02139**  
Phone (617) 253-4824  
Fax (617) 253-7014  
E-mail: info@ligo.mit.edu

**LIGO Hanford Observatory**  
**P.O. Box 1970**  
**Mail Stop S9-02**  
**Richland WA 99352**  
Phone 509-372-8106  
Fax 509-372-8137

**LIGO Livingston Observatory**  
**P.O. Box 940**  
**Livingston, LA 70754**  
Phone 225-686-3100  
Fax 225-686-7189

<http://www.ligo.caltech.edu/>

**Abstract**

The design requirements for the Advanced LIGO Input Optics Subsystem include the requirements for the RF modulation of the light, acquisition and operation of the mode cleaner, mode matching of the light to the interferometer, and beam steering into the interferometer. The scope of the IO includes the following hardware: phase modulation Pockels cells, photodetectors and related protective shutter (if needed), cabling, active jitter suppression system, mode cleaner optics, fabrication of suspensions, Faraday isolator, and mode matching telescopes.

# 1 Introduction

## 1.1 Purpose

The purpose of this document is to describe the design requirements for the Input Optics (IO) subsystem. Primary requirements are derived ('flowed down') from LIGO principal science requirements. Secondary requirements, which govern Detector performance through interactions between IO and other Detector subsystems, have been allocated by Detector Systems Engineering.

## 1.2 Applicable Documents

### 1.2.1 LIGO Documents

- [1] LIGO-T010075, "Advanced LIGO Systems Design", P. Fritschel, et al.
- [2] LIGO-M990288, "LIGO 2 Conceptual Project Book"
- [3] LIGO-E990303, "Seismic Isolation Subsystem Design Requirements Document", P. Fritschel, et al.
- [4] LIGO-T010076, "Optical Layout for Advanced LIGO", D. Coyne
- [5] LIGO-T020022, "Pointing Requirements in Advanced LIGO, Part I", G. Mueller, et al.
- [6] LIGO T020021, "Sideband Requirements in Advanced LIGO, Part I", G. Mueller, et al.
- [7] LIGO T020025, "EO-Modulators for Advanced LIGO, Part I", G. Mueller et al.
- [8] LIGO-T000053-01-D "Cavity Optics Suspension Subsystem Design Requirements Document, P. Willems, et al.

## 2 General description

### 2.1 Product Functions

The IO conditions the laser light so that its properties are compatible with the primary scientific requirements for Advanced LIGO. This function separates into the following seven categories.

Figure 2 Overall IO Product Specification

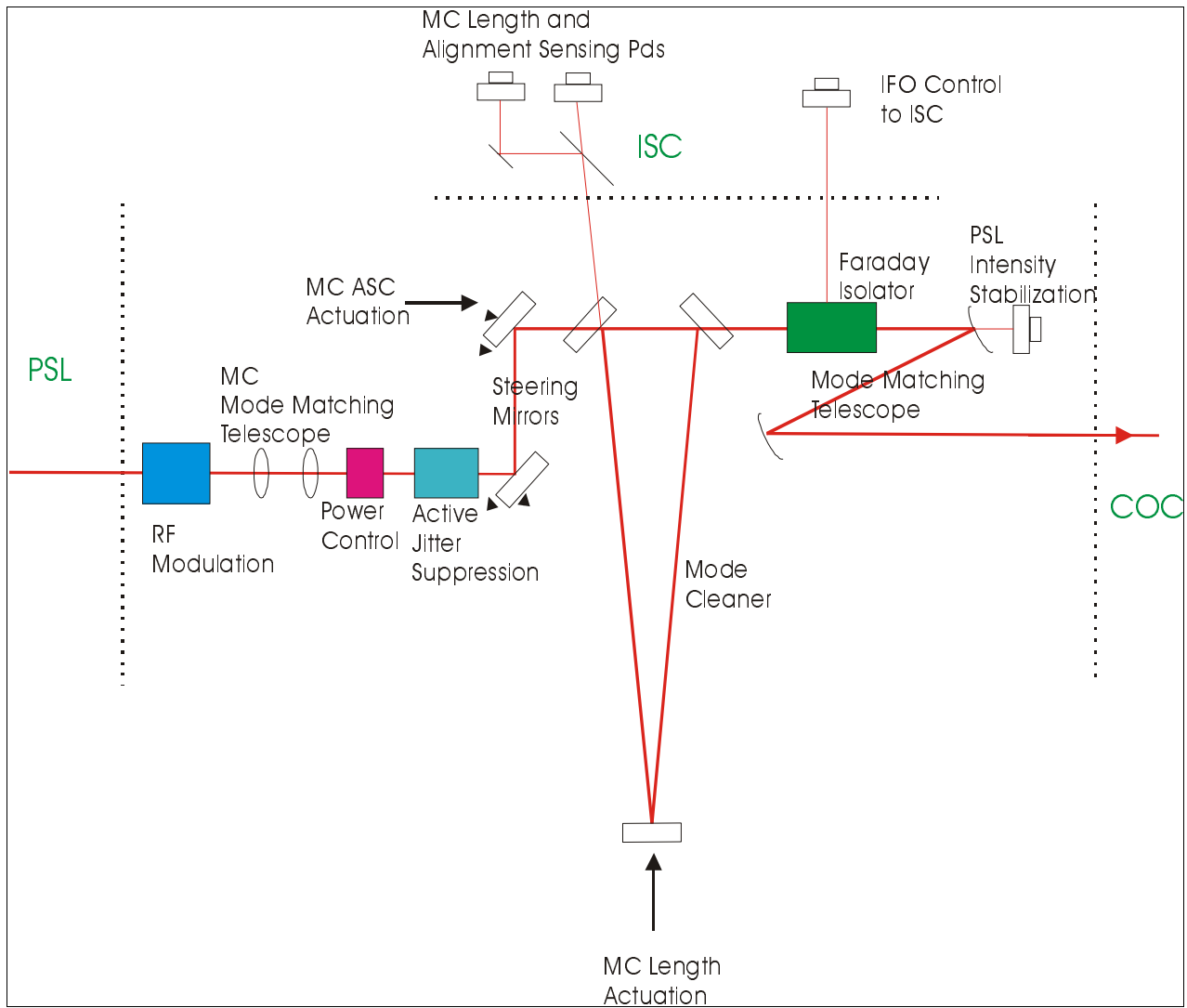

### 2.1.1 RF Modulation

The ISC subsystems require frequency components of the laser light (sidebands) for controlling the interferometer. The IO must provide for the production and monitoring of these sidebands using RF signals from the ISC.

Specifically, the IO provides:

- the design, fabrication, and assembly of all RF electro-optic modulators for the production of sidebands for controlling the interferometer and mode cleaner length and alignment sensing systems, including ancillary optical and mechanical components as needed.

The IO does not provide:

- RF signals to drive the oscillators.

### 2.1.2 Mode Cleaning

The laser light must be frequency stabilized and spatially filtered before it can be used to provide length and alignment sensing for the IFO. This is accomplished through a mode cleaner cavity.

Specifically, the IO provides:

- the design, fabrication, and assembly of a suspended, in-vacuum triangular mode cleaner cavity for active frequency suppression through feedback to the PSL, passive frequency noise suppression above its cavity pole frequency, and passive spatial filtering at all frequencies.
- diagnostic beams needed for locking and aligning the mode cleaner.
- the design, fabrication, and assembly of ancillary optical and mechanical components for mode-matching and steering beams into and out of the mode cleaner.

The IO does not provide:

- the design and implementation of the mode cleaner length and alignment controls.
- the design of the mode cleaner and steering mirror suspensions.

### 2.1.3 Additional Active Jitter Suppression

Given the expected level of jitter from the PSL, additional spatial stabilization will be needed in before the mode cleaner. A jitter suppression system provides active stabilization of the laser beam in the GW band.

Specifically, the IO provides:

- the design, fabrication, and assembly of an active jitter suppression system, including optical and mechanical components.
- the design of the controls required for this system.

The IO does not include:

- the fabrication and assembly of the electronics.

### 2.1.4 Power Control

The interferometer will be operated at variable power levels during installation, commissioning, and operation. An actuator to adjust the optical power is required.

Specifically, the IO will provide:

- the design, fabrication, and assembly of a power adjustment system including the optical and mechanical components.

The IO does not provide:

- control signals for power adjustment
- intensity stabilization of the PSL

### 2.1.5 IFO Mode Matching

The light must be delivered to the IFO with a proper Gaussian mode so that it will resonate in the IFO and not be rejected. Thus the IO provides for the mode matching of the light between the mode cleaner and the core optics components of the interferometer.

Specifically, the IO provides:

- the design, fabrication, and assembly of the mode-matching telescope (MMT) capable of accommodating small deviations from design specification in the core optics and providing optimal mode-matching for the different operational powers (currently 20 W and 125 W<sup>1</sup>).

The IO does not provide:

- the design of the MMT suspensions
- the fabrication of the large MMT suspension.

### 2.1.6 Optical Isolation of the PSL and Distribution of ISC Signals

The IO must provide optical isolation between the COC and the PSL. In addition, the ISC requires optical pick-off signals for controlling the length and alignment of the IFO.

Specifically, the IO provides:

- the design, fabrication, and assembly of an in-vacuum Faraday isolator capable of functioning over the entire power range of operation, including ancillary optical and mechanical components.
- diagnostic beams for other subsystems, including
  - a portion of the transmitted mode cleaner light for intensity stabilization of the PSL.
  - the reflected light from the power recycling mirror.

---

<sup>1</sup> LIGO-T010075, “Advanced LIGO Systems Design”, P. Fritschel, et al.

### 2.1.7 Internal Diagnostics

The IO must provide diagnostic capabilities for its own functions and for that of other subsystems where appropriate.

## 2.2 General Constraints

The IO is subject to the following constraints:

- The in-vacuum components of the IO must be contained in the current LLO and LHO vacuum envelopes (subject to the replacement of the HAM1,2 and 7,8 beam tube with a LIGO beam tube) and within the footprints of the Advanced LIGO seismic platforms.<sup>2</sup>

## 2.3 Assumptions and Dependencies

The following factors have been assumed in this document, and are, to the best of our knowledge, consistent with or have been flowed down from the Advanced LIGO Systems Design<sup>3</sup> and LIGO II Conceptual Project Book<sup>4</sup>; (configuration control established TBD SYS).

### 2.3.1 Suspensions

- Suspensions provided by SUS
  - GEO Triple Pendula suspensions for MC mirrors
  - Modified LIGO 1 SOS for SM, small MMT mirrors
  - Modified LIGO 1 LOS1 for final MMT mirror

---

<sup>2</sup> LIGO-T010076, “Optical Layout for Advanced LIGO”, D. Coyne

<sup>3</sup> LIGO-T010075, “Advanced LIGO Systems Design”, P. Fritschel, et al.

<sup>4</sup> LIGO-M990288, “LIGO 2 Conceptual Project Book”

<sup>5</sup> see footnote 1

<sup>6</sup> LIGO-T010075, “Advanced LIGO Systems Design”, P. Fritschel, et al.

<sup>7</sup> LIGO-E990303, “Seismic Isolation Subsystem Design Requirements Document”, P. Fritschel, et al.

### 3 Requirements

#### 3.1 Introduction

The IO subsystem derives its requirements, where available, from the top-level Advanced LIGO requirements for sensitivity and availability. The requirements are grouped into sections corresponding to the following functions of the IOO: RF modulation, mode cleaner, optical isolation, and IFO mode matching. At the present time, SYS is carrying both DC readout and RF modulation as possible detection schemes for Advanced LIGO. Where possible, we develop requirements for both methods.

The accompanying conceptual design document will present corresponding design for meeting these requirements.

**We derive all requirements below assuming that the related noise amplitude spectral density is held to 10% of the LIGO strain sensitivity  $h(f)$  at all in-band frequencies.**

#### 3.2 General IO Requirements

##### 3.2.1 Optical Efficiency

The net efficiency of IO TEM<sub>00</sub> optical power transmission from PSL output to COC input shall be 0.76 or greater, determined by the requirement that at least 125 W of TEM<sub>00</sub> light be coupled into the IFO. The optical power of the IO is defined as the sum for the carrier and sidebands.

##### 3.2.2 Output Beam In-band Alignment Stability (Jitter)<sup>8</sup>

Alignment fluctuations at the input of the COC couple to angular motion of the test masses to give in-band displacement signals. The (in-band) alignment stability of the entire IO subsystem shall not compromise that achieved directly after the mode cleaner, including the mode-matching telescope. The output beam alignment stability requirement is:

- DC readout – contributions from the carrier jitter coupled to ITM differential tilts dominate the noise contribution. We find:

$$\varepsilon_1(f) < \sqrt{\left(\frac{2.5 \times 10^{-5}}{f^2}\right)^2 + (5 \times 10^{-10})^2} \frac{[2 \times 10^{-8}]}{\Delta\Theta_{ITM}} \frac{1}{\sqrt{\text{Hz}}}$$

where  $\varepsilon_1$  is the amplitude of the 10,01 modes, and  $\Delta\Theta_{ITM} = \Theta_{ITM1} - \Theta_{ITM2}$  is the total differential tilt of the ITMs

- RF readout – contributions from RF sidebands beating against the pointing fluctuations of the carrier as well as the carrier beating against the pointing fluctuations of the sidebands contribute to the noise. We find:

---

<sup>8</sup> LIGO-T020022, “Pointing Requirements in Advanced LIGO, Part I”, G. Mueller, et al.



$$\varepsilon_1(f) < \sqrt{\left(\frac{4.5 \times 10^{-5}}{f^2}\right)^2 + (5.5 \times 10^{-10})^2} \frac{[2 \times 10^{-8}]}{\Delta\Theta_{ITM}} \frac{1}{\sqrt{Hz}}$$

### 3.2.3 Parasitic Interferometers

Light that reflects or scatters into the Rayleigh angle of the beam contributes to the in-band signal directly (through phase modulation at GW frequencies) and indirectly (through frequency shifting of scattered and reflected light into GW band due to mirror motions). Carrier light which propagates through transmissive optics can be upconverted to in-band noise through seismic excitation via the Fizeau effect. Carrier and sideband light reflecting off of mirrors can be directly upconverted to in-band signals through the Doppler effect. In addition, spurious cavities can be formed by light that reflects back to normal incidence optical components. We require:

- For optical components located on the PSL table, the frequency noise must be limited to 10% PSL frequency noise specification:
  - $\delta v(f) < 1 (10\text{Hz}/f)^2 \text{ Hz/Hz}^{1/2} \quad f < 100 \text{ Hz}$
  - $\delta v(f) < 10^{-2} (100\text{Hz}/f) \text{ Hz/Hz}^{1/2} \quad f > 100 \text{ Hz}$
- For optical components located after the MC, the frequency noise must be limited to 10% of the MC requirement:
  - $\delta v(f) < 3 \times 10^{-4} \text{ Hz/Hz}^{1/2} \quad (10 \text{ Hz}/f) \text{ to } 1 \text{ kHz}$
  - $\delta v(f) < 3 \times 10^{-6} \text{ Hz/Hz}^{1/2} \quad f > 1 \text{ kHz}$

## 3.3 RF Modulation Requirements

The IO provides the optical modulation for the RF sidebands used in the length and alignment sensing. The requirements include modulation frequencies, modulation depths, and relative stability of the mode cleaner resonance and modulation frequency and amplitude.

### 3.3.1 Modulation Frequencies

The IFO requires frequencies which resonate in the interferometer and mode cleaner as well as for alignment sensing and control. Currently, SYS is carrying both DC readout and RF readout as candidates for detection. All frequencies (chosen by ISC) must pass through the mode cleaner and therefore be integral multiples of the mode cleaner free spectral range.

- The IO must provide RF modulation in the range 0 – 200 MHz

### 3.3.2 Modulation Depths

Modulation depths are set by GW shot noise considerations at the asymmetric port. In addition, the IO must provide for a range of modulations about the specified depths to accommodate diagnostic functions and potential degradation.

- The IO must provide for modulation depths in the range  $m=0-0.5$

### 3.3.3 Modulation Amplitude Stability<sup>9</sup>

Intensity fluctuations on the carrier and sidebands, caused by changes in the modulation index  $\delta\Gamma$  or by RFAM in the modulators can mimic a gravitational wave signal. For the LSC sidebands, we require:

- DC readout – laser RIN of the carrier couples to arm cavity imbalances producing displacement noise driven by radiation pressure. Fluctuations in the modulation index produce additional carrier RIN. This leads to a requirement of

$$\delta m < 10^{-10}/\text{Hz}^{1/2} (1/\Gamma) (f/\text{Hz})$$

- RF readout
  - for  $f < 100$  Hz, carrier RIN coupled to arm imbalances limits sensitivity, as in DC readout.

$$\delta m < 10^{-10}/\text{Hz}^{1/2} (1/\Gamma) (f/\text{Hz}), f < 100 \text{ Hz}$$

- for  $f > 100$  Hz, fluctuations in the sideband intensities limit GW readout sensitivity.

$$\delta m < 10^{-8}/\text{Hz}^{1/2} (1/\Gamma), f > 100 \text{ Hz}$$

### 3.3.4 Modulation Frequency Stability<sup>11</sup>

Fluctuations in the modulation frequency due to oscillator phase noise beat at the asymmetric port photodetector produce technical noise. By computing the transfer functions of the phase noise to the dark port and setting equal to the allowed power fluctuation and converting to single sideband oscillator intensity noise, we find (for RF Readout):

- $I_{\text{SSB}} (10 \text{ Hz}) < -92 \text{ dBc/Hz}$
- $I_{\text{SSB}} (100 \text{ Hz}) < -140 \text{ dBc/Hz}$
- $I_{\text{SSB}} (1 \text{ kHz}) < -163 \text{ dBc/Hz}$

(See figure 1 of ref. 5 for frequency dependence.)

<sup>9</sup> LIGO T020021, “Sideband Requirements in Advanced LIGO, Part I”, G. Mueller, et al.

<sup>10</sup> LIGO T020025, “EO-Modulators for Advanced LIGO, Part I”, G. Mueller et al.

<sup>11</sup> LIGO T020021, “Sideband Requirements in Advanced LIGO, Part I”, G. Mueller, et al.

### 3.3.5 Modulation Cross Products

TBR PENDING DETAILED ANALYSIS OF ISC DESIGN There are 3 modulation frequencies in use (including the modulation for the mode cleaner. The modulation process produces intermodulation products (sidebands on sidebands). These intermodulation products can mix down into the GW band and produce technical noise. These modulation cross products look like fluctuations in the modulation frequency and have identical requirements:

- $I_{IM} (10 \text{ Hz}) < -92 \text{ dBc/Hz}$
- $I_{IM} (100 \text{ Hz}) < -140 \text{ dBc/Hz}$
- $I_{IM} (1 \text{ kHz}) < -163 \text{ dBc/Hz}$

## 3.4 Mode Cleaner Requirements

The mode cleaner provides frequency and spatial stabilization of the laser light, as well as intensity stabilization above its pole frequency.

### 3.4.1 Mode Cleaner Frequency and Intensity Stabilization

The SYS frequency noise requirement of  $\sim 3 \times 10^{-6} \text{ Hz/Hz}^{1/2}$  ( $4 \times 10^{-7} \text{ Hz/Hz}^{1/2}$ ) for DC readout (RF readout) on the light at the IFO input requires a mode cleaner frequency stability consistent with ISC loop gains and expected PSL frequency noise. We require:

- $\delta v(f) < 3 \times 10^{-2} \text{ Hz/Hz}^{1/2} (\text{Hz}/f)$  to 1 kHz
- $\delta v(f) < 3 \times 10^{-5} \text{ Hz/Hz}^{1/2}$   $f > 1 \text{ kHz}$

This limits the changes in the mode cleaner length to be below:

- $\delta L(f) < 3.6 \times 10^{-15} \text{ m/Hz}^{1/2} (\text{Hz}/f)$   $f < 1 \text{ kHz}$
- $\delta L(f) < 3.6 \times 10^{-18} \text{ m/Hz}^{1/2}$   $f > 1 \text{ kHz}$

The length changes caused by technical radiation pressure noise are:

- $\delta L(f) = 6.75 \times 10^{-14} \text{ m/Hz}^{1/2} \times (\text{kg/m}) \times (RIN(f)/10^{-9}) \times (P/100\text{kW}) \times (\text{Hz}/f)^2$

The fused silica mirrors which comprise the mode cleaner have a mass of  $m=3.8 \text{ kg}$ . The relative intensity noise limited by the assumed asymmetries in the arm cavities is:

- $RIN(f) < 2 \times 10^{-10} (f/\text{Hz})$  for DC-Sensing

corresponding to length changes of:

- $3.6 \times 10^{-15} \text{ m/Hz}^{1/2} (\text{Hz}/f)$

The requirements for the RIN for RF-Sensing are the same in the low frequency region ( $< 100 \text{ Hz}$ ) and even more stringent in the high frequency region ( $> 100 \text{ Hz}$ ). Subsequently, the radiation pressure noise in the mode cleaner is similar or lower than for DC-Sensing.

### 3.4.2 Mode Cleaner Alignment<sup>12</sup>

The MC alignment requirement is given by:

- Low frequency – the frequency stability of the laser field must not be compromised by beam jitter, giving:

$$\Delta\Theta_{MC} < 10^{-7} \text{ rad(rms)}$$

These requirements can be viewed as a trade off between alignment of the MC and beam jitter. Relaxing the requirements on mode cleaner alignment will reduce our sensitivity, especially in the high frequency GW band, or require tightening the requirements on beam jitter in that frequency region. However, we note that a better mode cleaner alignment than the one given above would not result in relaxed beam jitter requirements unless we also tighten the requirements on the alignment of the core optical components.

- In-band - the MC jitter rejection must not be compromised by MC mirror angular fluctuation noise, giving:

$$\delta\Theta_{MC}(f) < \sqrt{\left(\frac{6.25 \times 10^{-12}}{f^2}\right)^2 + (5 \times 10^{-15})^2} \frac{[2 \times 10^{-8} \text{ rad}]}{\Delta\Theta_{ITM}} \frac{1}{\sqrt{\text{Hz}}}$$

### 3.4.3 Mode Cleaner FSR stability

The requirements for oscillator phase noise and modulation amplitude stability presented above assume that the mode cleaner FSR matches the modulation frequency. Detuning of the modulation frequency from the mode cleaner FSR couples oscillator phase noise to produce modulation index instabilities. This will increase the intensity fluctuations in the carrier through the intensity feedback loop and would lead to even more stringent requirements for the modulation amplitude variations. The calculated requirements presented above are valid as long as the detuning between the FSR and the modulation frequency is below 14 Hz<sup>13</sup>.

In addition, the optimum demodulation phases will depend on the relative phases between carrier and sidebands. Changes in the FSR require in principle a readjustment of the demodulation phases to zero offsets in the error signals. The effect on the signal cannot be evaluated without a detailed length sensing and control scheme (**TBR**).

### 3.4.4 Mode Cleaner Beam Centering

The beam spot must be centered in the mode cleaner mirrors to a precision of 1 mm to avoid length-misalignment couplings.<sup>14</sup>

---

<sup>12</sup> “Pointing Requirements in Advanced LIGO, Part I”, G. Mueller, et al.

<sup>13</sup> LIGO-T020021-00-D “Sideband Requirements in Advanced LIGO, Part I”

<sup>14</sup> LIGO-T000053-01-D “Cavity Optics Suspension Subsystem Design Requirements Document, P. Willems, et al.

### 3.4.5 Availability Requirements

The IO availability will be limited by the lock acquisition time of the mode cleaner, and any degradation in performance due to thermal stress or optical contamination. We require:

- **Lock acquisition time to fully operational state < 20 sec**

### 3.5 Optical Isolation Requirements

Optical isolation is required to separate the PSL from IFO and IO back reflected light. The required isolation level is 30 dB (TBR).

### 3.6 Power Control

The Input Optics shall provide adjustable power to the interferometer for diagnostic and operational functions. We require:

- power range: 0 – 165 W (full PSL power)
- power increment: TBD
- that the power control optics do not compromise the frequency or amplitude performance of the PSL.

### 3.7 IFO Mode Matching

#### 3.7.1 Mode Matching Coupling Efficiency

The coupling efficiency from the Input Optics to the Main Interferometer GW carrier and sidebands  $TEM_{00}$ , mode parameters as described in interfaces, (COC) shall be 0.95 or higher. The telescope will provide this level of coupling with adjustability to accommodate deviations in COC specifications and thermal lensing effects. This is for the optimal alignment, and includes both low-order mismatching and more general high-order distortions.

#### 3.7.2 Mode Matching Telescope Alignment

Perturbations of the mode matching telescope may enhance the coupling of noise sources to gravitational wave noise (in band) and reduce coupling efficiency into COC (low frequency). We require that any telescopic magnification of pointing drift or jitter does not compromise the alignment stability of the IO output beam into the COC:

- Low frequency drift: telescope pointing must be consistent with COC coupling efficiency requirements of 0.95 or better:
  - the IO will furnish a diagnostic capability for measuring  $\Delta\Theta_{MMT}$  for each MMT mirror at a level consistent with this requirement.
- Low frequency mode mismatch
  - the IO will furnish a diagnostic capability for determining  $\Delta w$ , the deviation from the ideal arm cavity beam waist size, and  $\Delta\theta$ , the deviation from the ideal arm beam divergence angle

- the IOO will provide a method for in-situ correction of  $\Delta w$  and  $\Delta\theta$
- In-band noise: telescope angular and displacement fluctuations must be consistent with ASC requirements for beam jitter at the input of the COC:<sup>15</sup>
  - $\delta\Theta_{\text{MMT}}(f) < 10^{-12}/\text{Hz}^{1/2}$

### 3.8 Diagnostics

The diagnostic mode will provide the means to determine the proper functioning of the IO, and provide measurement of the performance of other subsystems. The following diagnostic capabilities are required of the IO (does not include diagnostics for MC ISC):

- IO Diagnostics
  - internal Qs of MC mirrors
  - Qs of MC suspensions
  - diagonalization state of MC optics
  - MC spatial stabilization
  - MC alignment and leveling
  - MC storage time
  - MC response to laser light pointing, frequency and intensity modulation
  - modulation sideband amplitudes and frequencies
  - RFAM level
  - MC beam centering
  - IFO mode matching efficiency
  - MC FSR stability
  -
- Diagnostic Services
  - open loop mode cleaner mirror seismic excitation
  - variations in RF sideband modulation depth
  - variations in IFO mode matching efficiency
  - sideband detuning from mode cleaner resonance
  - variation in optical power

### 3.9 Other Requirements

The Input Optics shall meet all generic subsystem requirements as documented in XXXXX, LIGO-T02xxxx, D. Coyne.

---

<sup>15</sup> LIGO-T020022, “Pointing Requirements in Advanced LIGO, Part I”, G. Mueller, et al.

Electro-Optic Countermeasures Electro-Optical Frequency (300 to  $3 \times 10^7$  GHz) Electronic Protection (similar to older terms of ECCM and DECM) Environmental Protection Agency Electrically Programmable Read-only Memory Electronic Counter-Countermeasures (also Protection) Requirements and Assessment Manual Effective Radiated Power Electronic Surveillance (similar to older term of ESM) Electrostatic Discharge Electronic Support Measures (similar to newer term of ES) Evolved Sea.Â Failure Mode and Effects Analysis Foreign Military Sale(s) Full Operational Capability Foreign Object Damage Force Combat Air Patrol Follow-On Test and Evaluation Fiber Optic Towed Device For Official Use Only Field of View Focal Plane Array feet per... [9] LIGO-E010613, Generic Requirements & Standards for Detector Subsystems [10] Upgrading the Input Optics for High Power Operation, LIGO- T060267-00-D [11] Modulators and Isolators for Advanced LIGO, LIGO-G060361-00-D [12] Advanced LIGO Input Optics Conceptual Design Document, LIGO T-020027-00-D [13] Advanced LIGO Input Optics Preliminary Design Document, LIGO T-060629-00-D.Â 3.1 Introduction The IO subsystem derives its requirements, where available, from the top-level Advanced LIGO requirements for sensitivity and availability. The requirements are grouped into sections corresponding to the following functions of the IOO: RF modulation, mode cleaner, optical isolation, and IFO mode matching. This document sets out the design requirements and interface specifications for the Advanced LIGO cavity optics suspensions system. Most of the requirements are derived by flow-down from the Advanced LIGO Systems Design (T010075-00). [reference added]. The scope of this document is limited to the specific requirements for the suspension subsystem (SUS) for the sensitive cavity optics, namely the input and end test masses, the power- and signal-recycling mirrors, the beamsplitter, the folding mirrors (the folded interferometer only), and the mode cleaner mirrors. In formal systems engineering documents, requirements can be thresholds or goals; thresholds are something that must be achieved, whereas goals have some degree of usefulness or desirability, but are not necessarily mandatory. Requirements are generally stated as "shall," whereas goals are stated as "should."Â The thermal design activity is not performed in isolation and requires inputs from other areas. These inputs typically consist of the geometric configuration of the spacecraft and the design details of subsystems. Material data are included in this input, since properties such as thermal capacitance, conductivity and IR, and solar radiation characteristics are needed to perform the thermal design. Input / Output & Forms Design - In an information system, input is the raw data that is processed to produce output. During the input design, the developers must consider the input devices used.Â Therefore, the quality of system input determines the quality of system output. Well-designed input forms and screens have following properties:Â To develop the output design that meets the end users requirements. To deliver the appropriate quantity of output. To form the output in appropriate format and direct it to the right person.